

## Datasheet module PVM-025-1

The PVM-025-1 module is designed to hold one 25 cm 1-channel ceramic membrane tube for use in pervaporation or vapour permeation applications.

Standard membranes:	Hybrid Silica, (Optimised) Silica, PDMS, PEBA or POMS
Housing material:	SS316L
Membrane area:	0,005 m <sup>2</sup>
Feed, Retentate conn.:	1/4" FNPT
Permeate conn.:	NW16 KF
Pressure Gauge conn.:	1/4" FNPT
Sealing of membrane tubes:	O-ring (EPDM-PC, VITON, FFKM)
Sealing of flange:	Gasket or O-ring (EPDM-PC, VITON, FFKM, Teflon)
Dimensions:	See figure

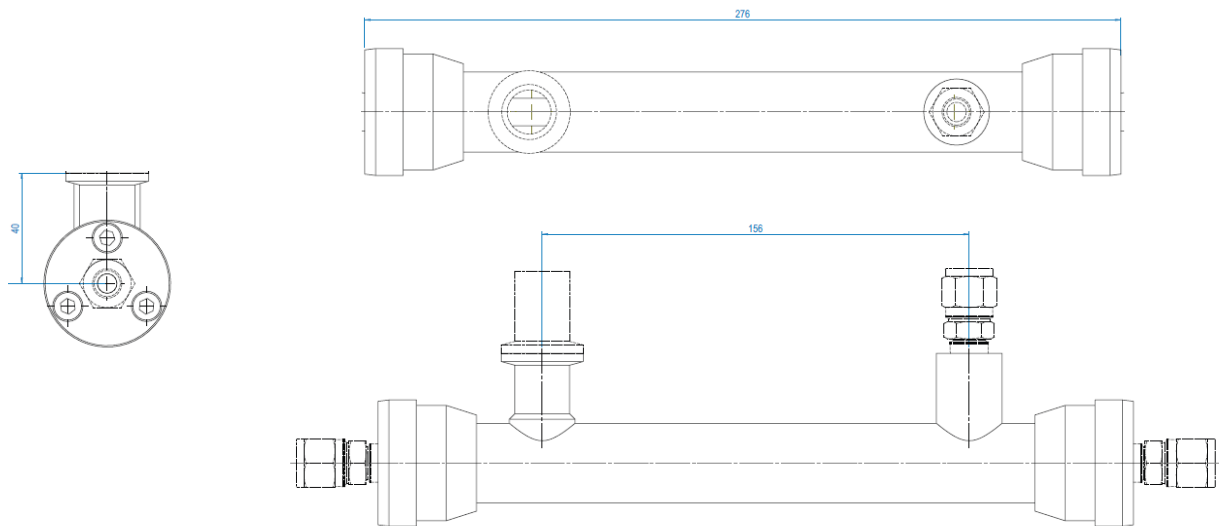

### Limits of Operation

Max. process pressure:	10 bar
Max. process temperature:	Depending on membrane and sealing type
Vacuum:	1 mbar
Feed pump capacity:	up to 500 L/hr
Cleaning:	General cleaning products for SS316. Further depending on membrane and sealing.