

## Datasheet module PVM-120-19-P

The PVM-120-19-P module is designed to hold 19 pieces 120 cm 4-tube ceramic membrane assemblies for use in pervaporation or vapour permeation applications.

Standard membranes:	Hybrid Silica, (Optimised) Silica, PDMS, PEBA or POMS
Housing material:	SS316L
Membrane area:	2,0 m <sup>2</sup>
Membrane configuration:	Parallel
Feed, Retentate conn.:	182-ANSI B 16.5 2"
Permeate conn.:	182-ANSI B 16.5 6"
Drain.:	3/8" FNPT
Sealing of membrane tubes:	O-ring (EPDM-PC, VITON, FFKM) or spring seal (Teflon-Hastelloy)
Sealing of flange and plates:	Gasket (Teflon)
Dimensions:	See figure

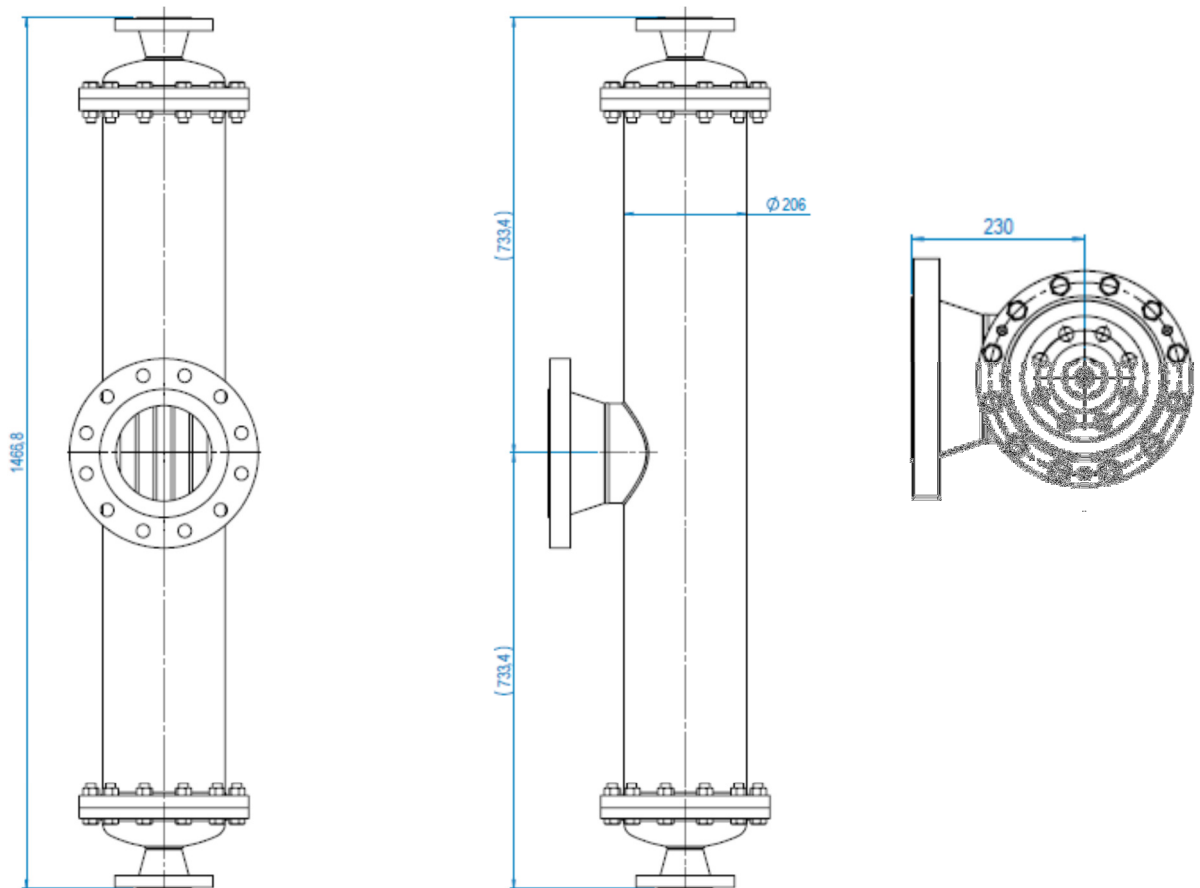

### Limits of Operation

Max. process pressure:	10 bar
Max. process temperature:	Depending on membrane and sealing type
Vacuum:	1 mbar
Feed pump capacity:	up to 38000 L/hr
Cleaning:	General cleaning products for SS316. Further depending on membrane and sealing.