

Datasheet: Application Pervaporation Test Unit PTU-054

The unit is developed to conduct application pervaporation process experiments with the PERVATECH membranes.

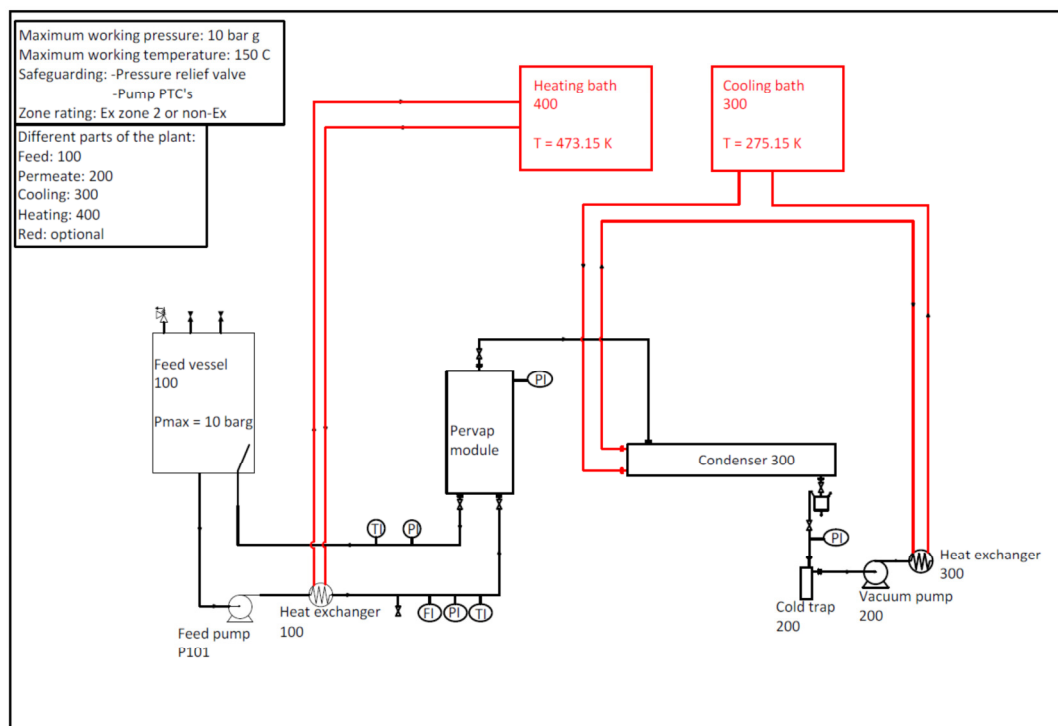

The base unit consists of:

- Frame, SS 316 tubing, appendages
- Maximum temperature: 100 degrees Celsius
- Maximum pressure: 10 bar relative
- Feed vessel 5 litre SS 316 and piping SS 316
- Frequency controlled magnet driven turbine pump
- Analogue flow and feed pressure indicators
- Digital temperature and vacuum pressure indicators
- In-line heat-exchanger to heat-up feed with oil or steam
- Vacuum pump, non-Ex to be placed remotely with additional atm. condenser and vacuum control
- Permeate collection:
 1. Fractionated condensation with condenser and additional P indicator (included in PTU-054 unit)
 2. Duplex cold trap with coolant -20°C to -196°C (liquid N_2)
- 4-tube module type PVM-043, including 4 ceramic pervaporation membranes (50 cm length, 10x7 mm (odxid), type t.b.d. by customer)
- Electric control cabinet
- Manual

Excluded:

- Heating and cooling units

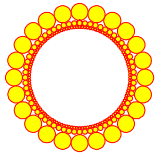
**Options:**

- Ex version, components zone 1, certified for zone 2 (vacuum pump, heating bath and control cabinet to be placed remotely)
- Flat Sheet Test Cell membrane module for organophilic membrane sheets
- Alternative construction material for feed contacting parts (e.g. SS316Ti, Hastelloy) if required based on feed chemical corrosion properties

Process description of the Application Tester:

The feed stream is re-circulated over the module, meanwhile transporting the permeate through the membrane with vacuum applied on the permeate side.

The feed (liquid) comes from the feed tank (capacity of 5 litre), and is regulated by a frequency controlled magnet driven feed pump, which facilitates also the re-circulation over the module. The feed tank is heated by an inline tube and shell heat-exchanger. Temperature control by thermocouple and safety limit set by a second thermocouple.

The cross-flow over the membrane can be set by the frequency controller of the feed pump. Typical liquid linear velocity through the membrane module is about 1,5 to 2 m/sec, to prevent concentration polarization. Lower velocities will reduce the refreshing of the species to be transported through the membrane.

The permeate vapour which is left after condensation step is liquefied in the cold traps using liquid nitrogen, dry ice/acetone or any coolant serving the condensation as required.

Vacuum is established by means of a non-Ex dry membrane vacuum pump which is placed remotely.

Remarks:

- The design is based on the standard flow sheet for this system
- Commissioning on site is not included, which has to be agreed upon when placing the order
- Instruction and basic training on site is not included, instructions are presented in the manual
- Travel and lodging expenses, if necessary, are not included
- Final design of the base frame to be discussed